

# MAXI JOLLY HC MD 50

Direct current dimmable (TRAILING EDGE-LEADING EDGE) electronic drivers with DIP-SWITCH  
Alimentatori elettronici regolabili (IGBT-TRIAC) in corrente continua con DIP-SWITCH

Made in Italy



IS 15885  
(Part 2 / Sec 13)  
S (4)  
R - 41049751



MAXI JOLLY HC MD



MAXI JOLLY HC MD BI



Article Articolo	Code Codice	P out W	V out DC	I out DC	U out V	ta °C	tc °C	λ max. Power Factor	η max. Efficiency <sup>(1)</sup>
DC MAXI JOLLY HC MD <sup>(3)</sup>	127550	45	2...43	1,05 A cost.	55	-25... +45 <sup>(3)</sup> /50 <sup>(6)</sup>	80 <sup>(3)</sup> 85 <sup>(6)</sup>	0,95 <sup>(2)</sup>	> 88
DC MAXI JOLLY HC MD BI <sup>(5)</sup>	127552	50	2...42	1,2 A cost.					
		50	2...36	1,4 A cost.					
		50	2...31	1,6 A cost.					
		50	2...28	1,75 A cost.					
		50	2...23	2,1 A cost.					

<sup>(1)</sup> Referred to  $V_m = 230$  V, 100% load - Riferito a  $V_m = 230$  V, carico 100%

<sup>(2)</sup> Pout > 25 W

<sup>(4)</sup> 127550BIS:

order code for BIS marked product  
codice di ordine per il prodotto marchiato BIS

#### Accessories not supplied - Accessori non a corredo

Article - Articolo	Code - Codice
ETDU29 (12.2)	180426
ETD2E9 (12.2)	180427



ETD2E9



ETDU29

#### Features

- Double terminal blocks to loop other driver (max. 5 A).<sup>(3)</sup>
- Multipower driver supplied with dip-switch for the selection of the output current.
- IP20 independent driver, for indoor use.
- Class I protection against electric shock for direct or indirect contact.
- It can be used for lighting equipment in protection class I.
- Active Power Factor Corrector.
- Current regulation  $\pm 5$  % including temperature variations.
- Input and output terminal blocks on the same side (wire cross-section up to 1,5 - 2,5 mm<sup>2</sup> / AWG15 - AWG13).
- Clamping screws on primary and secondary circuits for cables with diameter: min. 3 mm - max. 8 mm.
- Protections:
  - against overheating and short circuits;
  - against mains voltage spikes;
  - against overloads.
- Thermal protection = C.5.a.

#### Caratteristiche

- Doppia morsettiera lato rete per rimando ad altro alimentatore (max. 5 A).<sup>(3)</sup>
- Alimentatore multipotenza fornito di dip-switch per la selezione della corrente in uscita.
- Alimentatore indipendente IP20, per uso interno.
- Protetto in classe I contro le scosse elettriche per contatti diretti e indiretti.
- Utilizzabile per apparecchi di illuminazione in classe di protezione I.
- PFC attivo.
- Corrente regolata  $\pm 5$  % incluse variazioni di temperatura.
- Morsetti di entrata e uscita sullo stesso lato (sezione cavo fino a 1,5 - 2,5 mm<sup>2</sup> / AWG15 - AWG13).
- Serracavo su primario e secondario per cavi di diametro: min. 3 mm - max. 8 mm.
- Protezioni:
  - termica e cortocircuito;
  - contro le extra-tensioni di rete;
  - contro i sovraccarichi.
- Protezione termica = C.5.a.

**Rated Voltage**  
Tensione Nominale  
220 ÷ 240 V

**Frequency**  
Frequenza  
50-60 Hz

**AC Operation range**  
Tensione di utilizzo AC  
198 ÷ 264 V

**Power - Potenza**  
1 ÷ 50 W

**iTHD**  
 $\leq 15\%$  <sup>(1)</sup>

**Stand by power**  
 $\leq 0,5$  W

**Output current ripple**  
 $\leq 3\%$  <sup>(1)</sup>

**Standards compliance**  
EN 50172 (VDE 0108)

EN 55015  
EN 60598-1  
EN 61000-3-2  
EN 61000-3-3  
EN 61347-1  
EN 61347-2-13  
EN 61547  
EN 62384  
VDE 0710-T14

**Max. pcs for CB B16A**  
(see page info17)  
30 pcs

**In rush current**  
10A 200μsec



3.1.3

Dimmable multipower drivers - Compact case - PHASE CUT  
Alimentatori multipotenza regolabili - Formato compatto - TAGLIO DI FASE

**Direct current dimmable (TRAILING EDGE-LEADING EDGE) electronic drivers with DIP-SWITCH**  
**Alimentatori elettronici regolabili (IGBT-TRIAC) in corrente continua con DIP-SWITCH**

Made in Italy

**IP 20** **SCREW FIXING**  $\varnothing 88$  3,46" Weight - Peso gr. 240 / 8,5 oz.  
 Pcs - Pezzi 40

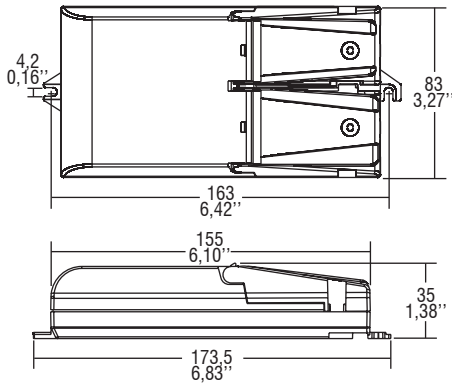

**BUILT-IN** **SCREW FIXING** Weight - Peso gr. 235 / 8,3 oz.  
 Pcs - Pezzi 40  
 Compatible with ZHAGA (AM2)

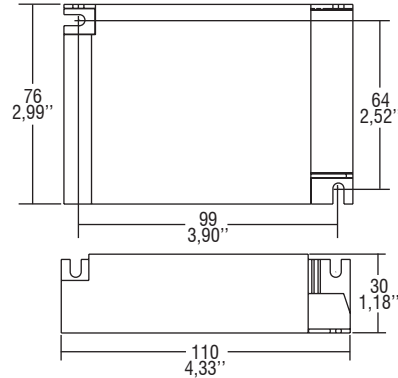

**Wiring diagram - Schema di collegamento** (Max. LED distance on page info8 - Massima distanza LED a pagina info8)

### DC MAXI JOLLY HC MD

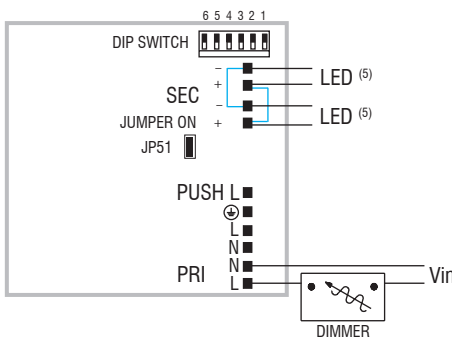

**PHASE-OUT dimming** - To avoid flickering, keep the slaves at 100% dimming level.  
 Dimmerazione TAGLIO DI FASE - Per evitare flicker, i singoli slaves devono essere lasciati con dimming 100%.  
[Internally wired - Collegato all'interno.](#)

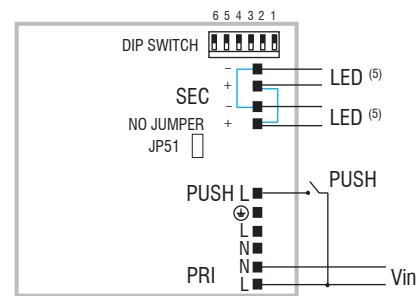

**PUSH diagram - Collegamento PUSH**  
[Internally wired - Collegato all'interno.](#)

### DC MAXI JOLLY HC MD BI

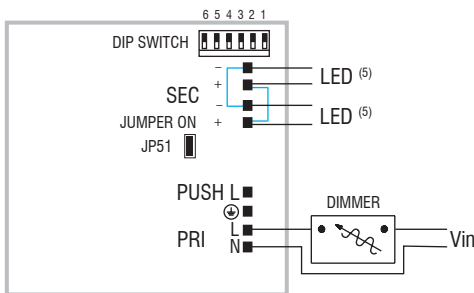

**PHASE-CUT dimming** - To avoid flickering, keep the slaves at 100% dimming level.  
 Dimmerazione TAGLIO DI FASE - Per evitare flicker, i singoli slaves devono essere lasciati con dimming 100%.  
[Internally wired - Collegato all'interno.](#)

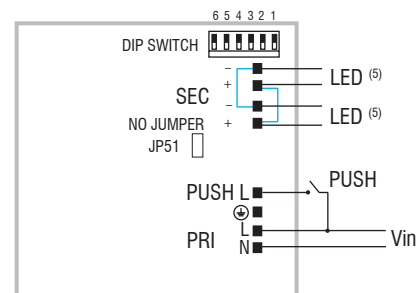

**PUSH diagram - Collegamento PUSH**  
[Internally wired - Collegato all'interno.](#)

### Operation Mode

- Regulating driver with "phase cut-off" dimmer IGBT, TRIAC and PUSH.
  - Light regulation 0/0,5 - 100 % by means of PUSH function (mains voltage):
    - a short push to turn on and off;
    - a longer push to increase or decrease light intensity;
    - regulation automatically stops at minimum and maximum values;
    - for another on, regulation or off command, release the push button and give the desired command again;
    - dimming level memory at mains restore.
  - Maximum length of the cable, from push button to last transformer, must be max. 15 m / 49 ft. In case of applications where the cable is longer than 15 m / 49 ft, keep this separate from the 220 - 240 Volt mains cable.
  - ATTENTION: only use normally open push buttons with no incorporated warning light.
  - <sup>(6)</sup> For constant current LED load only 1 output should be connected. The 2 LED outputs can be connected only for constant voltage LED loads.
- For additional details for regulations see pages info12-14.

### Modalità di funzionamento

- Alimentatore regolabile con dimmer a "taglio di fase" IGBT, TRIAC e PUSH.
  - Regolazione della luminosità 0/0,5 - 100 % mediante la funzione PUSH (tensione di rete):
    - una pressione breve per accendere e spegnere;
    - una pressione prolungata per aumentare o diminuire l'intensità luminosa;
    - la regolazione si ferma automaticamente ai valori minimi e massimi;
    - per un nuovo comando accensione, regolazione o spegnimento, rilasciare il pulsante e dare nuovamente il comando desiderato;
    - ripristino del livello di dimming al ritorno alimentazione.
  - La lunghezza massima del cavo, dal pulsante all'ultimo trasformatore, deve essere max. 15 m / 49 ft. In caso di applicazioni dove il cavo superi i 15 m / 49 ft, tenere lo stesso separato dal cavo di rete 220 - 240 V.
  - ATTENZIONE: usare solo pulsanti di tipo normalmente aperto privi di spia luminosa incorporata.
  - <sup>(6)</sup> Per LED a corrente costante solo 1 uscita dovrebbe essere utilizzata. Le 2 uscite possono essere utilizzate solo per LED a tensione costante.
- Per ulteriori dettagli sulle regolazioni vedi pagine info12-14.

3.1.3

Dimmable multipower drivers - Compact case - PHASE CUT  
 Alimentatori multipotenza regolabili - Formato compatto - TAGLIO DI FASE